



Portfolio

Process solutions for
evaporation, distillation and drying

www.gigkarasek.com

Table of content

Thin film - / short path technology.....	4
Conventional evaporation technology.....	8
Technical center / pilot plants	12
Renewable carbon solutions	13
Services & technologies	14
Industries & application examples	15

About us

GIG Karasek is a global provider of high-quality process design and turnkey industrial plant engineering in thermal separation technologies. GIG Karasek has realized pilot plants and skid units up to turnkey industrial plants on an EPC basis worldwide.

Our entire planet is full of liquid industrial (waste) streams and impurified liquids. We are confronted daily with high pollution, low product qualities, and energy-intensive processes in industrial environments, which lead to global challenges. It is possible to separate liquids through their different boiling points and thermal behavior by harnessing energy-optimized **thermal separation technologies**. Technologies such as evaporation, distillation, and drying can concentrate waste streams, distillate valuable solvents, and recover essential media or dry sludges to obtain solid materials.

By implementing tube and plate type falling film, thin film and short path evaporation technologies, high viscous evaporators, distillation, rectification, and drying technologies, almost all media with different viscosities, boiling points, and thermal sensitivities could be processed by **GIG Karasek technologies**. Centered and deeply rooted in the German-speaking DACH Region, GIG Karasek has been utilizing the most modern technologies and fabrication knowledge over decades which will still be implemented in **industrial plants for generations to come**.

The headquarters, in Gloggnitz, focus on essential matters with highly experienced craftsmanship and a Pilot Test Centre close to Vienna. The engineering and fabrication center in Attnang Puchheim is in Austria's highly industrialized area. Lastly, the engineering office in Graz is located in the city of research and technology, where GIG Karasek engineers can deliver the **best available technologies** worldwide. By employing highly talented and experienced senior personnel and a global sales network, all industrial plant solutions can be realized successfully in the pulp-, food-, agro-, chemical-, fiber-, pharmaceutical- and biofuels industries.

History & milestones



Austrian locations

Attnang-Puchheim
4800, Industriestraße 21
Engineering & Fabrication
Thin-Film / Short-Path Technology

Gloggnitz-Stuppach
2640, Neusiedlerstraße 15-19
Production of Process Equipment
Evaporation Technology
R&D Centre

Graz
8055, Brauquartier 21, 1 OG., Top 9
Engineering & Plant Design
Evaporation Technology

Your benefits with GIG Karasek

- ◆ Many years of engineering expertise
- ◆ Optimum price-performance ratio
- ◆ Scale-up via internal pilot plant trials
- ◆ Secured spare parts service
- ◆ Individual process solution
- ◆ High manufacturing quality
- ◆ Efficient project execution

We produce all key components under strict quality controls in our factory and qualified sub-suppliers. **GIG Karasek** realizes for you basic & detailed engineering, manufacturing, procurement, installation, and startup services, everything from one hand. The success and development of **GIG Karasek** were only possible because of the constant idea of developing technologies for tomorrow. Constantly improving and newly inventing, not only to satisfy the customers but also to make a valuable contribution to the future.

Thin film - / short path technology

Complex tasks require special process solutions. The GIG Karasek **thin film- / short path technology** is used where traditional methods reach their limits. In addition, there are different types of evaporators for individual requirements. GIG Karasek has focused its concentrated **know-how in process- and apparatus engineering** on perfecting thin film technology and has established highly specific thin film evaporators as ideal solutions for demanding tasks in thermal separation technology.

The **diagram** shows the respective areas of application in evaporation technology. By choosing or combining the right technologies, GIG Karasek is able to handle a very wide range of different substances.

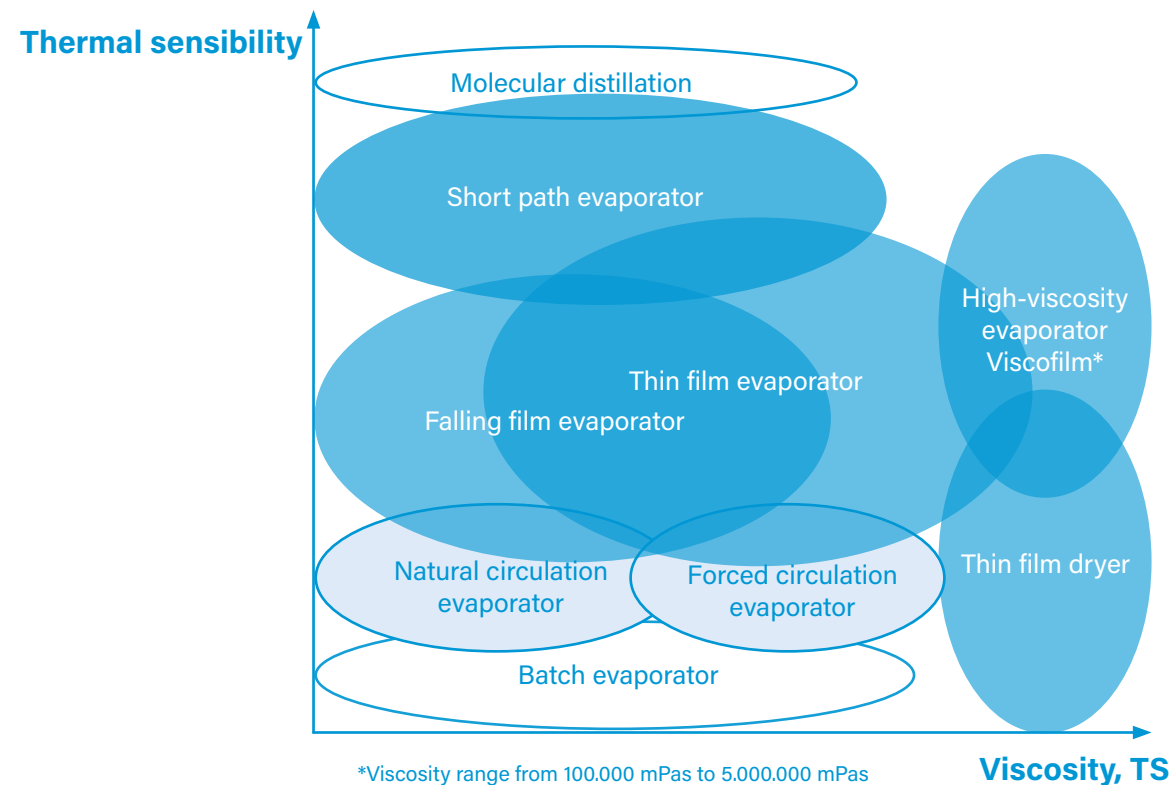

Classic operating conditions (Other challenges will be discussed separately)

Temperature:	≤ 390°C
Vacuum:	≥ 0,001 mbar abs.
Feed:	10 kg/h to 15,000 kg/h
Viscosity:	up to 50.000 mPas (in special cases up to 5.000.000 mPas)
Performance:	ATEX, GMP, API
Materials:	carbon steel, stainless steel (1.4301, 1.4404, 1.4562, 1.4539), hastelloy, titanium

1) Thin film evaporator

The **thin film evaporator** made of high-quality materials delivers the highest performance and can separate even the most sensitive products into required quantities. Depending on the production or product requirements, we develop customized solutions.

Their core: **individually selected evaporators with perfectly adapted rotor types**. We have a variety of different rotor and wiper blades. Through individual consultation we will find the perfect solution for your application.

Functionality

The **thin film evaporator** consists of a cylindrical, mechanically precisely machined heating surface with external heating and an internal rotor. The substance mixture is distributed over the circumference of the head by means of a rotating distributor system and flows downwards on the evaporator wall heated from the outside with steam or thermal oil. In this case, a uniform distribution and a liquid film is mechanically generated by means of wiper elements. Vortexes form highly turbulent heat transfer zones on the wiper blades which in addition to the good heat transfer achieved, also ensure a constant renewal of the product coming into contact with the heating surface. The result is a gentle evaporation process which ensures high quality of your product through the shortest possible contact with the heating surface and thus minimized temperature stress.

Field of application

Our **thin film evaporators** can be used both for concentration and for the purification of valuable substances. Exactly adapted to your requirements, the devices are particularly suitable for the following service areas:

- ◆ Concentration of temperature sensitive substances
- ◆ Concentration up to high viscous substances
- ◆ Concentration of structurally viscous substances
- ◆ Distillation of low boiling valuable substances
- ◆ Purification by distilling off valuable products from high boiling components
- ◆ Special applications such as reboiler for rectification plants

Advantages

- ◆ Individual design of the optimal heating surface and rotor type acc. your process requirement
- ◆ Optimised residence time of the product
- ◆ Improved heat transfer caused by turbulences from the wiper blades
- ◆ No additional lubrication required for selected rotor types
- ◆ Easy maintenance & spare parts service
- ◆ Short downtime and assembly time during maintenance / inspection
- ◆ Reduced risk of corrosion by using suitable materials
- ◆ Constantly renewed film

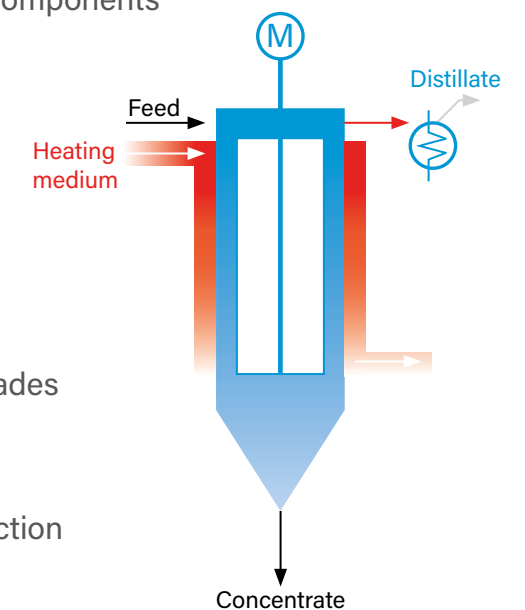

2) Thin film dryer

There are two types of thin film dryers: vertical and horizontal. The successful thin film evaporator principle ensures gentle drying processes if conventional systems reach their limits regarding heat-sensitive products.

Based on their wealth of experience and knowledge from separation technology, our experts realize high-performance **vertical and horizontal thin film dryers**, which are satisfying both economically and technically.

Functionality

The product is continuously distributed over the entire circumference of the heating wall. With the help of special wiper elements, the wall contact is constantly renewed, and the product flow is simultaneously transported further. The rotor blades do not touch the heating jacket but prevent encrustation or blocking of the heating surface using solidly constructed wiper elements arranged with a defined gap. This wiper design enables liquid feed products to be dried up to powder form.

The various units can be used individually or in combination, allowing the operator to benefit from the advantages of different evaporator designs.

Field of application

The thin film dryer is mainly used in the waste, chemical-, oleochemistry and in the food industry. Products such as:

- ◆ Sludges (sewage sludge, process sludge, industrial sludge and municipal sludge)
- ◆ Chemical products (preproducts and intermediates)
- ◆ Products of fatty acid industry
- ◆ Saline solutions
- ◆ Moisture solids
- ◆ Suspensions
- ◆ Pastes

Advantages

- ◆ Granted high dryness
- ◆ Minimal product loss
- ◆ High product purity
- ◆ Gentle evaporation due to short residence and permanent product circulation
- ◆ No deposits on the heating surfaces due to mechanical cleaning
- ◆ Reduced maintenance through clever design in the bearing and mechanical seal area

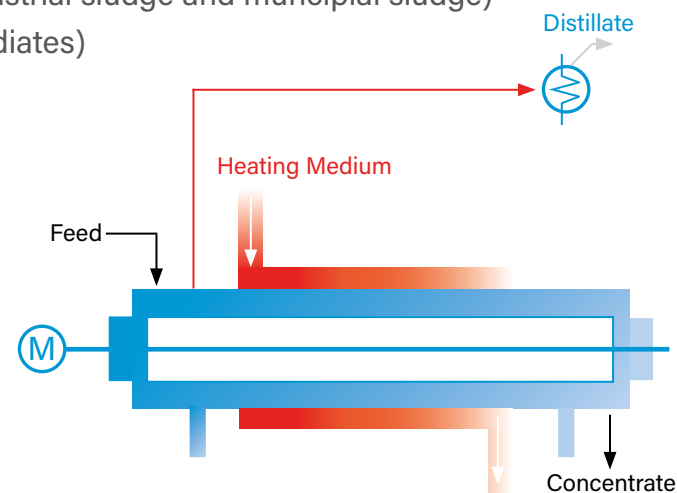

3) Short path evaporator

The GIG Karasek **short path evaporator** impresses with a particularly wide performance spectrum in the field of gentle evaporation technology for sensitive substances.

This special apparatus is able to achieve an extremely **fine vacuum** for distillation at pressures down to 0.001 mbara.

Functionality

The short path evaporator works on the same high-performance principle as the thin-film evaporator. The difference is that it has an integrated condenser. As a result, the path of the vapors to the condenser is extremely short, which is why it gets its name.

Field of application

Short path evaporators are mainly used for distilling viscous products at low process pressures (0.001 – 1 mbara):

- ◆ Obtaining fatty acids, derivatives or semi volatile flavorings
- ◆ Separation of extracts
- ◆ Distillation of vitamins
- ◆ Distillation of oils

Advantages

- ◆ Extraordinary gentle evaporation through low pressure losses
- ◆ Suitable for the distillative purification of many substances that would not be conventionally separated by other thermal processes
- ◆ High boilers do not reach the condenser thanks to efficient droplet separators

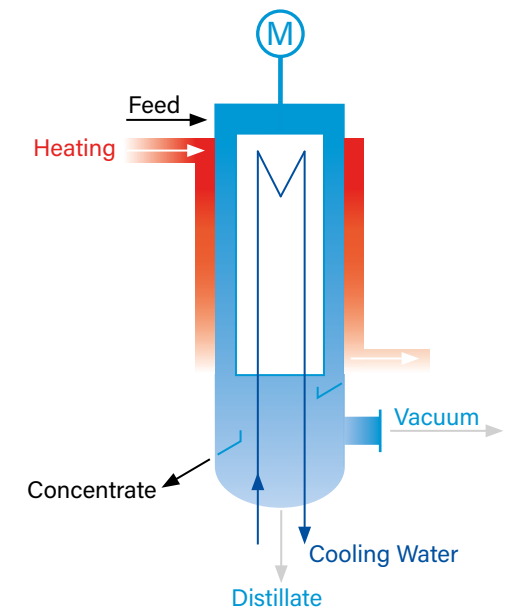

Thin film evaporator

Thin film dryer

Short path evaporator





Conventional evaporation technology

There are different types of evaporators and process solutions for individual requirements. GIG Karasek has focused its process and apparatus engineering know-how on perfecting **falling film technology**. The plate and tube falling film evaporators are ideal for high evaporation rates, substances with low viscosities, and common thermal sensitivities.

1) Multiple effect evaporation (MEE)

In **multiple effect evaporation**, the vapor from the liquid medium is used to heat the subsequent stages. As a result, the use of live steam can be significantly reduced, and the plant can be operated cost- and energy efficiently. The **flow-diagram** below shows a typical 6-effect evaporation plant as an example.

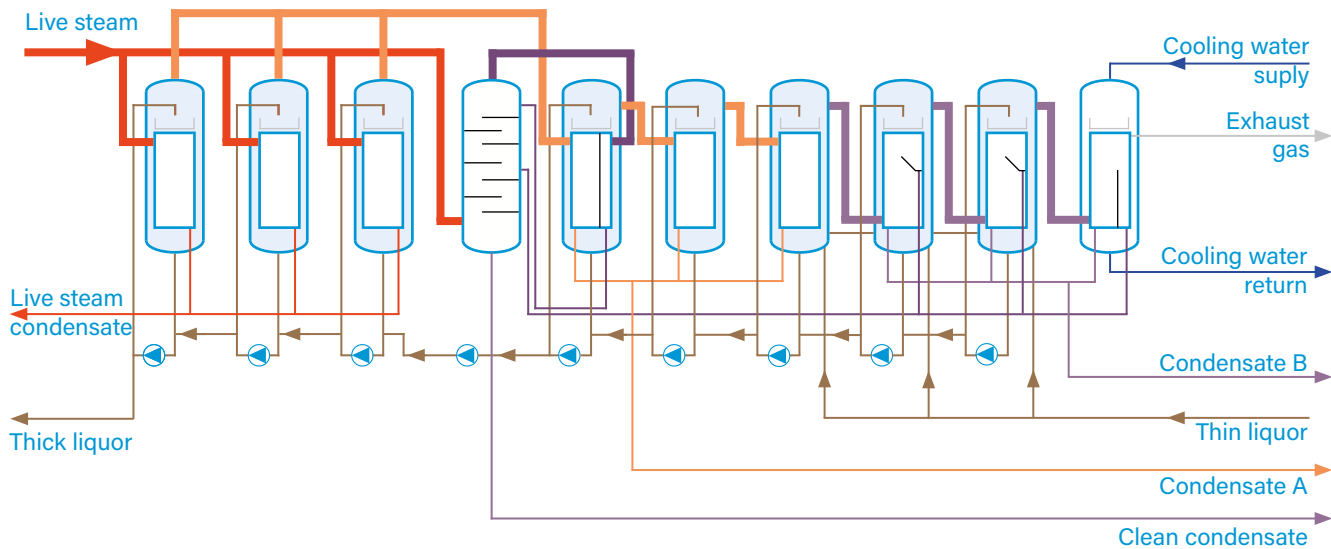

Functionality

Multiple effect evaporation plants are one of the most widely used processes for evaporation plants, especially with high evaporation capacities. The principle is simple: the first effect is heated with live steam, and the subsequent effect uses steam from the previous stage to heat the heating surfaces. With an increasing number of effects, live steam can be significantly reduced. However, the effects can not be arbitrarily increased since the maximum temperature gradient is usually predetermined. On the one hand, the temperature sensitivity of the medium and the maximum available heating steam pressure play a role, and on the other hand, the cooling water temperature. Thus, an optimum between energy and investment costs must be determined in close cooperation with the customer. An essential part is the process concept to find the optimal design for every system.

Advantages

- ◆ Individually optimized energy consumption
- ◆ Very high evaporation capacities are possible
- ◆ Ideal for mixtures with higher boiling point rise
- ◆ Reduction of energy costs by using multiple effects
- ◆ Improved condensate qualities through condensate segregation

2) Mechanical vapor recompression (MVR)

The biggest advantages of the mechanical vapor recompression are the significant reduction of live steam and cooling water demand and the reduction of the CO₂ footprint by using compressor power from renewable electricity.

Functionality

In the **mechanical vapor recompression plant**, the vapors are compressed by an electrically operated compressor and used again to heat the evaporator. Depending on the application (boiling point increase, heat transfer), one- or multiple-stage turbo-compressors work based on an open heat pump principle. Here, the steam (vapor) arising in the industrial processes is lifted to a higher temperature and thus higher energy level with a centrifugal fan and then returned to the process as heating steam. The energy contained in the steam is not lost. Only the energy required to increase the temperature must be additionally applied. Since the dramatic increase in energy costs in recent decades, efforts have been made to reduce the consumption of fossil fuels and CO₂ emissions, as well as to reduce the high levels of steam consumption for these processes. These efforts can be achieved with mechanical vapor recompression because it is a cost-effective and reliable process for evaporation, distillation, crystallization, and drying.

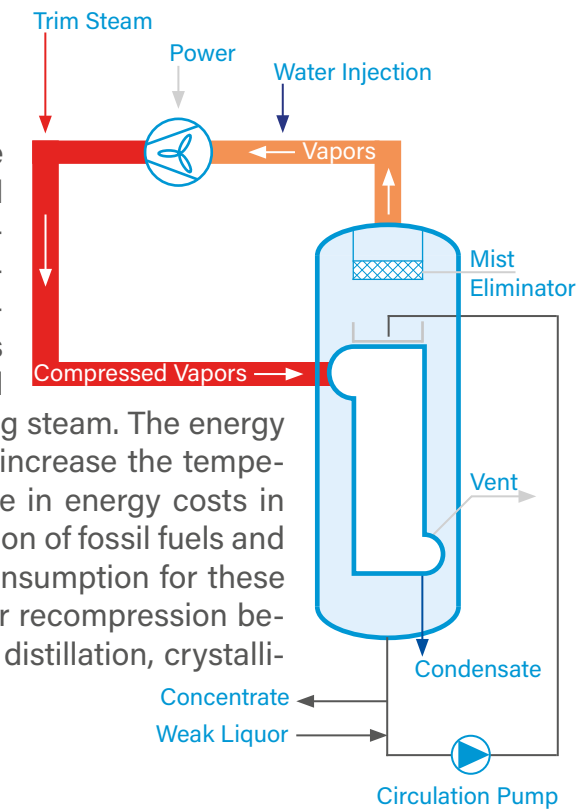

Advantages

- ◆ Little live steam demand
- ◆ Little cooling water demand
- ◆ Gentle evaporation temperature
- ◆ Minimum operational costs
- ◆ Reuse of low-pressure steam possible
- ◆ Reduced plant footprint

3) Thermal vapor recompression (TVR)

The biggest advantage of the **thermal vapor recompression** is energy saving through the re-use of vapors.

Functionality

The **thermal vapor recompression** builds on the same principle as the mechanical alternative but uses only a portion of the resulting vapor for heating the system. The steam compression for heat recovery occurs in a steam jet pump, which is usually designed for a specific operating point and works on the jet pump principle. A certain amount of steam, the so-called motive steam, is required to operate a thermal vapor compressor. The resulting energy savings correspond in many cases to about one additional evaporator stage.

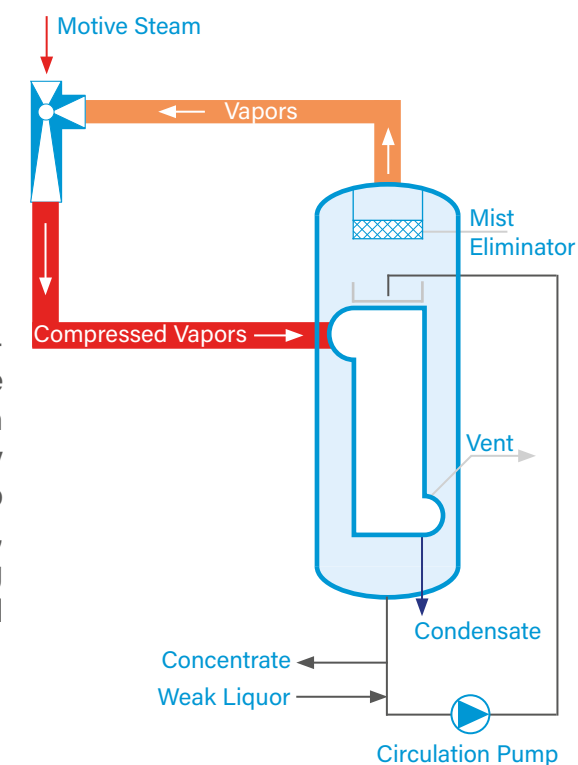



Plate falling film evaporator

The **plate falling film evaporator** is the ideal solution for media with a high fouling tendency. It is perfect for high evaporation rates and low viscosity substances. Plate falling film evaporators from GIG Karasek are characterized by engineering know-how over decades, excellent fabrication quality, best energy values, highest condensate qualities, and above average long operating times. Years of design experience, automation of processes, and welding know-how enable plate falling film evaporators to be the optimal solution for many processes.

Functionality

The core know-how of our **plate falling film evaporator** is welding the plate elements, which GIG Karasek has manufactured in-house for decades. By using induction, resistance-spot-welded heating elements are manufactured in different formats. Optimized and perfected over and over, these welding processes are characterized by high levels of automation, increased energy efficiency, and high productivity.

The **advantages** are a minimal tendency for scaling through self-cleaning effect and easy cleaning options, low risk of corrosion on the surface as the basic material structure remains unchanged at the spot weld surface, no cold deformation in the weld influence zone due to special devices, minimized risk of stress corrosion cracking. In addition, the welded edge brings maximum utilization of the heating surface, no gap, and the fully welded edge as a plated finish.

All this leads to very long operating times, a low risk of fouling and corrosion, and the highest quality of the heating elements of evaporation plants

Field of application

- ◆ Concentration of black liquor, sulfite spent liquor, waste liquors
- ◆ Recovery of solvents & alcohols ◆ Separation of water, solvents, alcohols
- ◆ Recovery of recyclables ◆ Volume reduction of liquid-liquid mixtures
- ◆ Separation of multicomponent mixtures ◆ and much more.

Advantages

- ◆ Ideal for fouling media
- ◆ Integrated mist eliminator
- ◆ Low circulating pump power required
- ◆ Highest evaporation capacities possible
- ◆ Self-cleaning effect and easy cleaning options
- ◆ Excellent separation of the liquid- and vapor phase
- ◆ Condensate segregation by realizing a secondary heating surface
- ◆ Small vapour velocities result in low pressure loss and low energy consumption

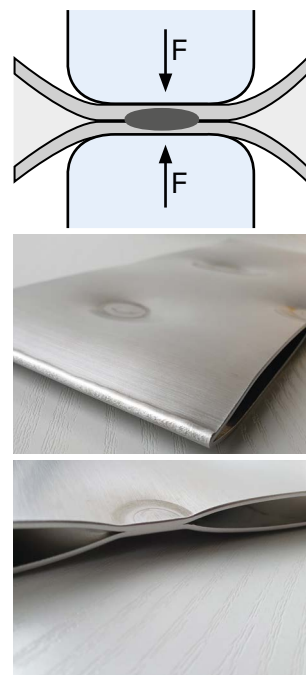

Tube falling film evaporator

Tube falling film evaporators are used in many standard evaporation applications. One of the main challenges faced with these evaporators is proper droplet separation and cleaning of the apparatus.

GIG Karasek brings in many years of experience and expertise to bear on the challenges in the design and manufacture of the tube falling film evaporators.

Functionality

Tube falling film evaporators are vertically oriented shell and tube heat exchangers. The product is evenly distributed via distribution trays on the evaporator's tube sheet. The liquid forms a thin film on the inner tube wall and flows down freely by gravity. Evaporation of the more volatile medium at the heating surface produces vapor, which is led in the tubes in co-current flow with the boiling liquid.

Subsequently, the vapor phase is separated from the liquid phase in the lower evaporator chamber via integrated demisters or cyclone separators. Typically, steam is used for heating the evaporator on the shell side.

Field of application

- ◆ Concentration of (waste) liquors with low tendency to foul
- ◆ Volume reduction of liquid-liquid mixtures
- ◆ Separation of multicomponent mixtures
- ◆ Separation of water, solvents, alcohols
- ◆ Recovery of solvents & alcohols
- ◆ Recovery of recyclables

Advantages

- ◆ Used across a variety of industries dealing with low fouling media
- ◆ Compact design and small plant footprint
- ◆ Ideal for little evaporation capacities



Multiple effect evaporation plant



Plate falling film evaporator

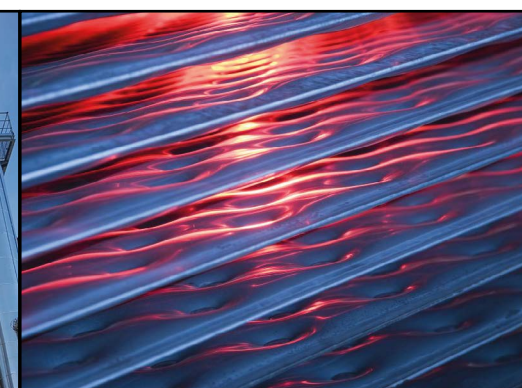

Tube falling film evaporator



Technical center / pilot plants

GIG Karasek runs its research center situated in Gloggnitz, Austria. The pilot plant's complete set of unit operations includes falling film evaporators, thin film evaporators, short path evaporators, high viscous evaporators, and thin film dryers. Thus we can generate actual process operating data, design your optimal strategy, and support you in finding the optimal process conditions under GIG Karasek's expert supervision.

Furthermore, we can generate samples for your internal evaluation as a service which can be done before capital expenditure. Under perfectly adapted conditions, field-proven specialists can subject your test material to meaningful laboratory and pilot tests. All systems are designed for high flexibility, are connectable, and can be configured and combined for various tasks.

We are always open to individual needs. From concept development to essential questions such as investment decisions, you will be accompanied by our experts. Only long-term and sustainable research and innovation activities deliver the necessary results to optimize our customers' processes in the future.

Advantage through innovation

Get to know new processes and convince yourself of innovative approaches: Our team will introduce you to the secrets of future-oriented process technology or develop further process steps as tailor-made special solutions explicitly for your challenges.

- ◆ Laboratory trials in small scale
- ◆ Pilot tests in demoplant scale
- ◆ Test reports incl. scale up

Test your product on a small scale

Many products require the definition of the optimal plant configuration and the inspection of the operating data. GIG Karasek offers you the easy possibility to test-produce your product on our laboratory-scale equipment. Instead of off-the-shelf technology, we realize customized scalable systems tailored to your processes and research goals.

Pilot plants

Pilot plants close the gap between laboratory and production facilities. Here, evaporation processes can be tested on a demoplant scale with different operating parameters according to your needs. In addition, all data for a later scale-up are determined.



Renewable carbon solutions

GIG Karasek is your partner for geosphere-free carbon-based product generation: from technology prototyping to industrialization and optimization.

With about 90 years of plant construction experience, GIG Karasek provides its customers with a **revolutionary technology that transforms captured CO₂ into value-added products** manufactured today from geosphere carbon. By using captured CO₂, water, and renewable energies, GIG Karasek helps its customers build individual-made plants to improve the CO₂ balance of their companies or, ideally, to balance it out to **save costs and meet carbon neutrality goals**.

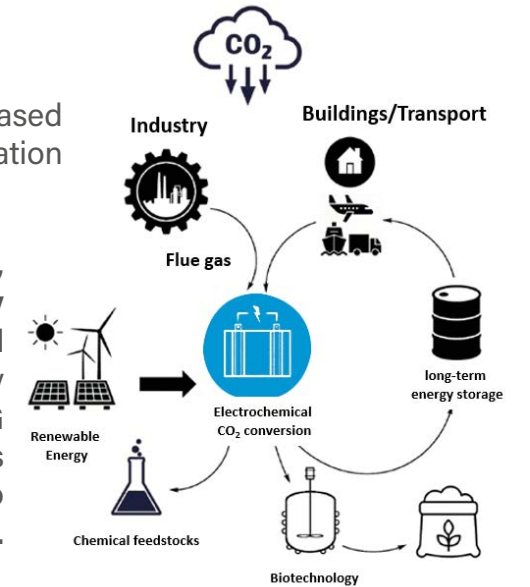

GIG Karasek differentiates itself from competitors **by offering a complete solution** using a specially designed catalyst, a suitable reactor cell, and cell peripheral engineering, as well as integrating well-founded, advanced process know-how for downstream concentrating of recyclable materials.



Utilization for economization and recovery

Innovative technologies promote competition and open up new market opportunities. Companies that use process solutions to capture and recycle CO₂ will save costs by reducing CO₂ emissions and generating profits with marketable products. With CO₂ taxes on the rise, return on investment (ROI) is expected to occur sooner rather than later. In addition, process solutions such as these form the basis for affordable, profitable, and environmentally friendly solutions for generations to come.

Increase the sustainability of your production processes

The European Green Deal is the European Union's overarching objective to become the first climate-neutral continent by 2050. The EU aims to reduce greenhouse gas emissions by 55 % by 2030 compared to 1990. European companies shall become world leaders in clean products and technologies. **GIG Karasek helps you identify and exploit your processes' sustainability and savings potential!**





Performance & services

- ◆ Project management
- ◆ Project controlling
- ◆ Engineering (basic, detail)
- ◆ Manufacturing & procurement
- ◆ Assembly & supervision
- ◆ Commissioning & training
- ◆ Turn-key-projects (EPC, EPS, EPCM, etc.)
- ◆ After sales & services

Optimization & modernization

- ◆ Revamping
- ◆ Retrofitting
- ◆ Debottlenecking

Technical center

- ◆ Laboratory tests
- ◆ Pilot tests
- ◆ Toll distillation

Consulting & studies

- ◆ Inventory survey incl. simulation models
- ◆ Development of expansion concepts
- ◆ Evaluation of savings potential
- ◆ Cleaning concepts
- ◆ Debottlenecking

Technologies

Conventional evaporation technologies

- ◆ Evaporator types:
 - Plate falling film evaporator
 - Tube falling film evaporator
 - Forced circulation evaporator
 - Rising film evaporator
- ◆ MEE - Multiple effect evaporation
- ◆ MVR - Mechanical vapor recompression
- ◆ TVR - Thermal vapor recompression

Thinfilm-/shortpath technology

- ◆ Evaporator types:
 - Thin film evaporator
 - Short path evaporator
 - High viscosity evaporator
- ◆ Thin film dryer:
 - horizontal
 - vertical
- ◆ Miniplant

Rectification / distillation

Renewable carbon solutions

Industries & application examples

Pulp & fiber industry ◆ Concentration of black liquor ◆ Concentration of sulfite spent liquor
◆ Concentration of liginosulfonates ◆ Concentration of bleachery waste water ◆ Concentration of xylose
◆ Recovery of solvents from the fiber industry ◆ Distillation of tall oil ◆ Concentration of dissolved pulps for textile industry ◆ Methanol distillation ◆ Turpentine separation ◆ Concentration of ionic liquids

Starch industry ◆ Concentration of steep- and washwater ◆ Concentration of sugar from the starch industry (glucose, fructose, dextrose, maltose, sorbitol) ◆ Concentration of sweeteners ◆ Concentration of modified starch

Oleochemistry - biodiesel, fatty acids ◆ Separation of dioxane from surfactants ◆ Removal of free fatty acids from mono-, di- and triglycerides ◆ Distillation of monoglycerides ◆ Distillation of fatty acids and resin acids from tall oil ◆ Distillation of fatty acid derivatives and fatty methylester
◆ Separation of residual glycerine from residues of biodiesel production ◆ Biodiesel purification according to EN 14214

Chemical industry ◆ Separation of nitric acid from organic high boiler ◆ Separation of butynediol from high boiler ◆ Recovery of methanol from high boiler ◆ Recovery of xylene from a cleaning solution ◆ Removal of hexane from PP and PE waxes ◆ Salt drying
◆ Separation of phenol from coal pitch ◆ Distillation of precursors for the production of insecticides
◆ Separation of by-products in the production of synthetic fibers

Plastics industry - polymers ◆ Separation of HDI, MDI and TDI monomers (isocyanates)
◆ Residual removal of toluene from epoxy resin ◆ Separation of THF from polymers ◆ Separation of trimethylpropane from high boiler ◆ Purification of silicone oils and silicone polymers ◆ Recovery of solvents
◆ Concentration and distillation of lactic acid for (e.g. PLA)

Petrochemistry ◆ Drying of lubricants for the forging industry ◆ Used oil distillation

Wastewater & recycling ◆ Drying of industrial sludges ◆ Drying and predrying of municipal sewage sludge ◆ Drying of hydroxide sludge

Food Industry ◆ Drying of lecithin, molasses ◆ Concentration of tartaric acid derivatives
◆ Concentration and distillation of lactic acid

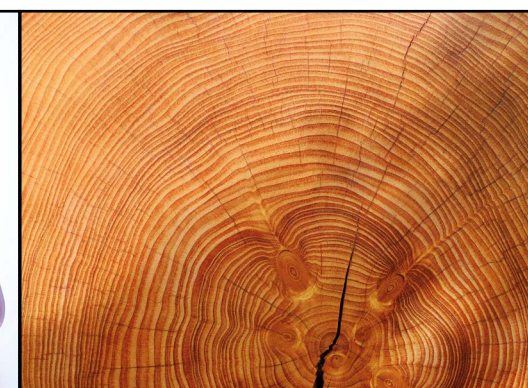



We develop individual process solutions and plants ◆ efficiently ◆ competently ◆ cooperatively
◆ proactively ◆ in a targeted way ◆ reliably and according to your requirements.

Regardless of the scope of services, we aim to optimize your production facilities with customized product quality and process solutions. Where traditional companies reach their limits, **GIG Karasek** finds ways to separate your liquids by combining different thermal separation technologies developed over decades. High competence and personal all-round service make **GIG Karasek** your reliable partner for unique challenges.



100 E valid from 08/2022

GIG Karasek GmbH
Neusiedlerstrasse 15-19
A-2640 Gloggnitz
☎ +43 / 2662 / 42780
office@gigkarasek.at

www.gigkarasek.com

